

THE NEXT STEP Antislip Alert Indicators



ADVANCE
ANTI-SLIP SURFACES P/L

30 years

Antislip Alert Indicators are proven to be an effective system of warning workers, contractors or visitors of any hazards or potentially hazardous areas that may be present. Antislip Alert Indicators will also serve as a prompt to always think of their safety.

The Advance Anti-Slip Surfaces Antislip Alert Indicator safety design method can be added to most of our Class 1, metal backed, antislip pedestrian safety products. Especially our Stair Nosing and Safeplates Antislip Alert Indicator messages can be of almost any description, incorporating standard safety signage formats, custom messages, or with a customer's company logo to create a corporate safety impact.

The Advance Anti-Slip Surfaces Antislip Alert Indicator safety range will provide secure footing even in the most extreme conditions and will eliminate slips, trips and falls in your workplace.

Please note: the product type and size will determine the message size and surface grade available.

ESCAPE ROUTE MARKERS

Advance Anti-Slip Surfaces Escape Route Markers are used to identify walkways and escape routes on surfaces where traditional painted lines are not able to be used, such as grating mesh. Escape Route markers are a cost-effective method to highlight safe access or egress around an entire facility.

Our Escape Route Markers can be supplied in a combination of standard sizes or with bespoke customised applications available upon request.

Escape Route Markers are able to be installed quickly and easily using our Universal Clamp Assemblies on grating mesh or mechanical fastening and adhesive on other surfaces.

Escape Route Markers (1200mm x 100mm) come in either metal backed antislip or FRP Antislip foundations.

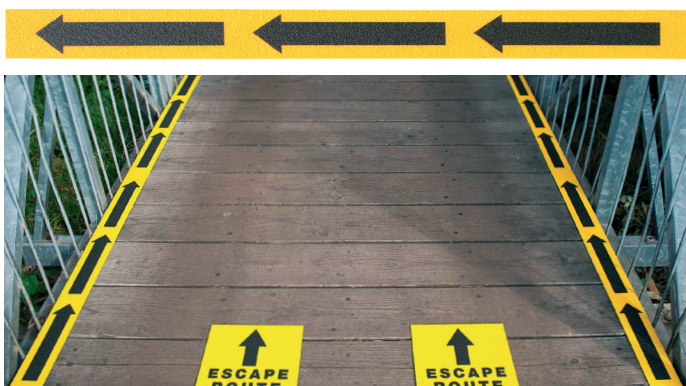

SAFETY MESSAGES

Some of the many options available in the Advance Anti-Slip Surfaces Antislip Alert Indicator safety range.



Think Safety
450mm x 300mm



Caution: Please Use Handrail
600mm x 450mm



Please mind The Step
450mm x 300mm



Overhead Crane Area
600mm x 450mm

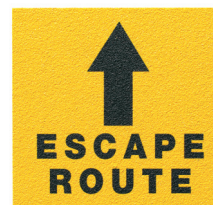

Escape Route
300mm x 300mm



Use Handrail
600mm x 200mm
750mm x 200mm
900mm x 200mm



Use Trailing Hand Technique
Stair Nosing – A.600mm
x B.180mm x C.20mm

WATCH YOUR STEP

Watch Your Step
600mm x 100mm
750mm x 100mm
900mm x 100mm





COMPANY LOGO

Company or corporate logo branding can also be provided on our antislip Stair Nosing and SafePlate range. Examples: AAS



UNIVERSAL CLAMP ASSEMBLY STANDARD 3 PIECE GALV

ADVANCE STAIR NOSING with The Next Step Antislip Alert Indicator

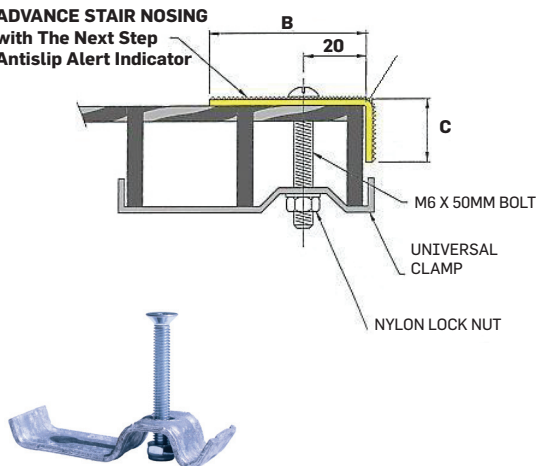

UNIVERSAL CLAMP ASSEMBLY RAPID 2 PART GALV

ADVANCE SAFEPLATE OR STRIP with The Next Step Antislip Alert Indicator

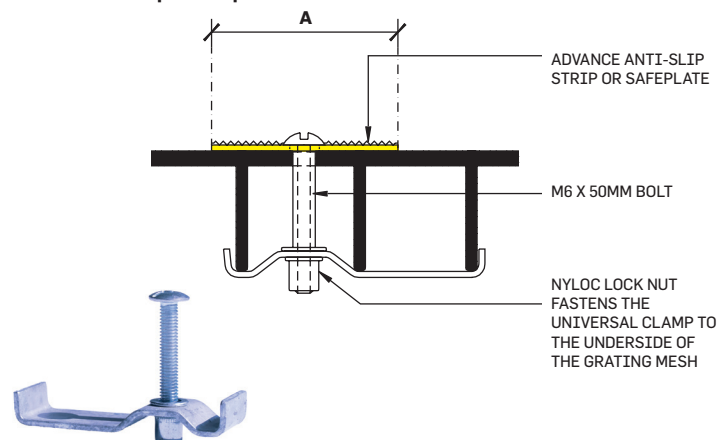

ADVANCE ANTI-SLIP SURFACES Pty. Ltd.

6A Aristoc Road, Glen Waverley 3150, Victoria, Australia

P: +61 3 9560 4488 F: +61 3 9562 0449 E: sales@advanceantislip.com

www.advanceantislip.com

Let every step you take be a safe one with Advance Anti-Slip Surfaces!